

DCN, ECN, ECR	LOCATION	REV	BY	DATE	REMARKS
-	-	-	CHK	-	-

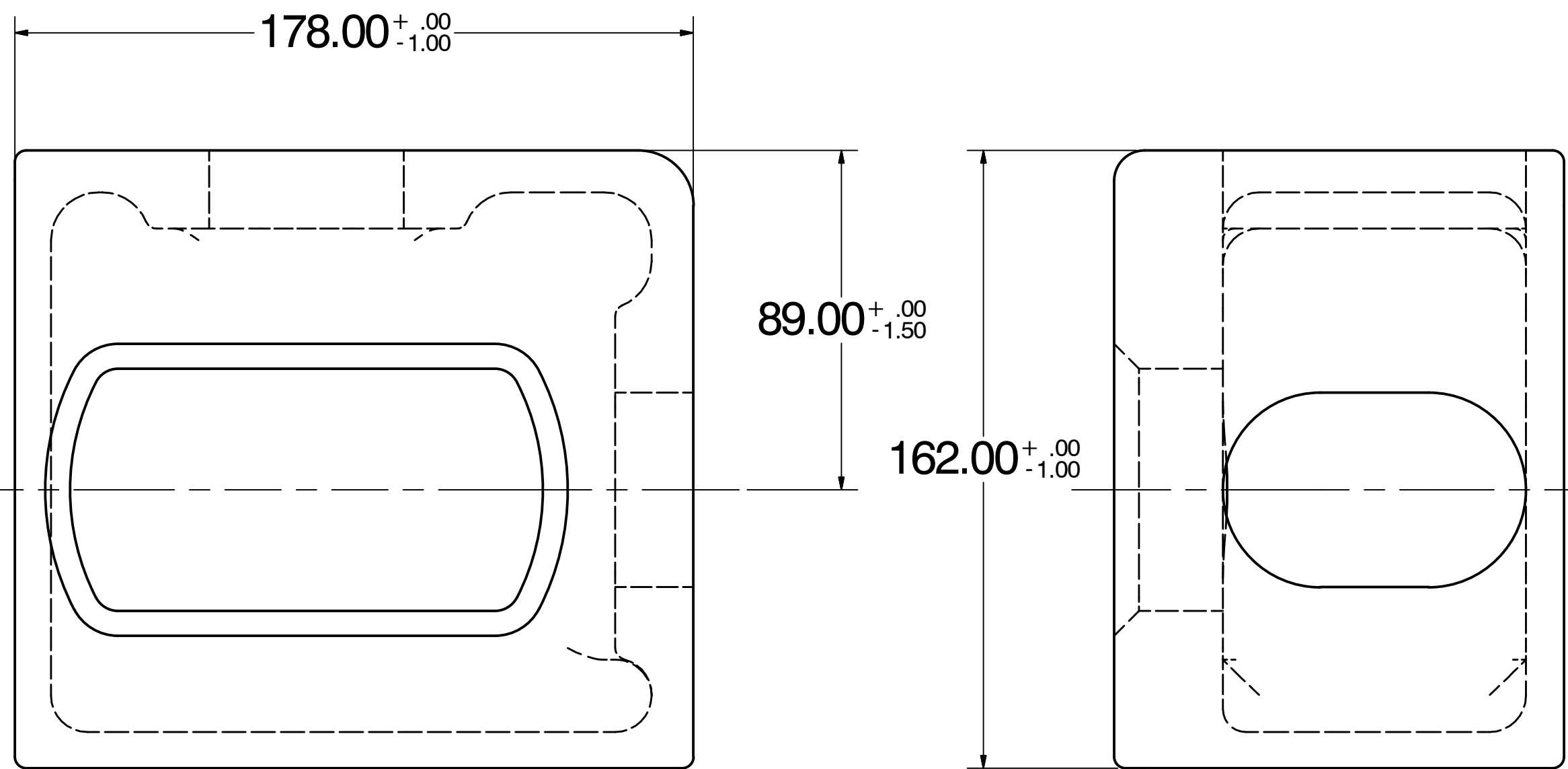
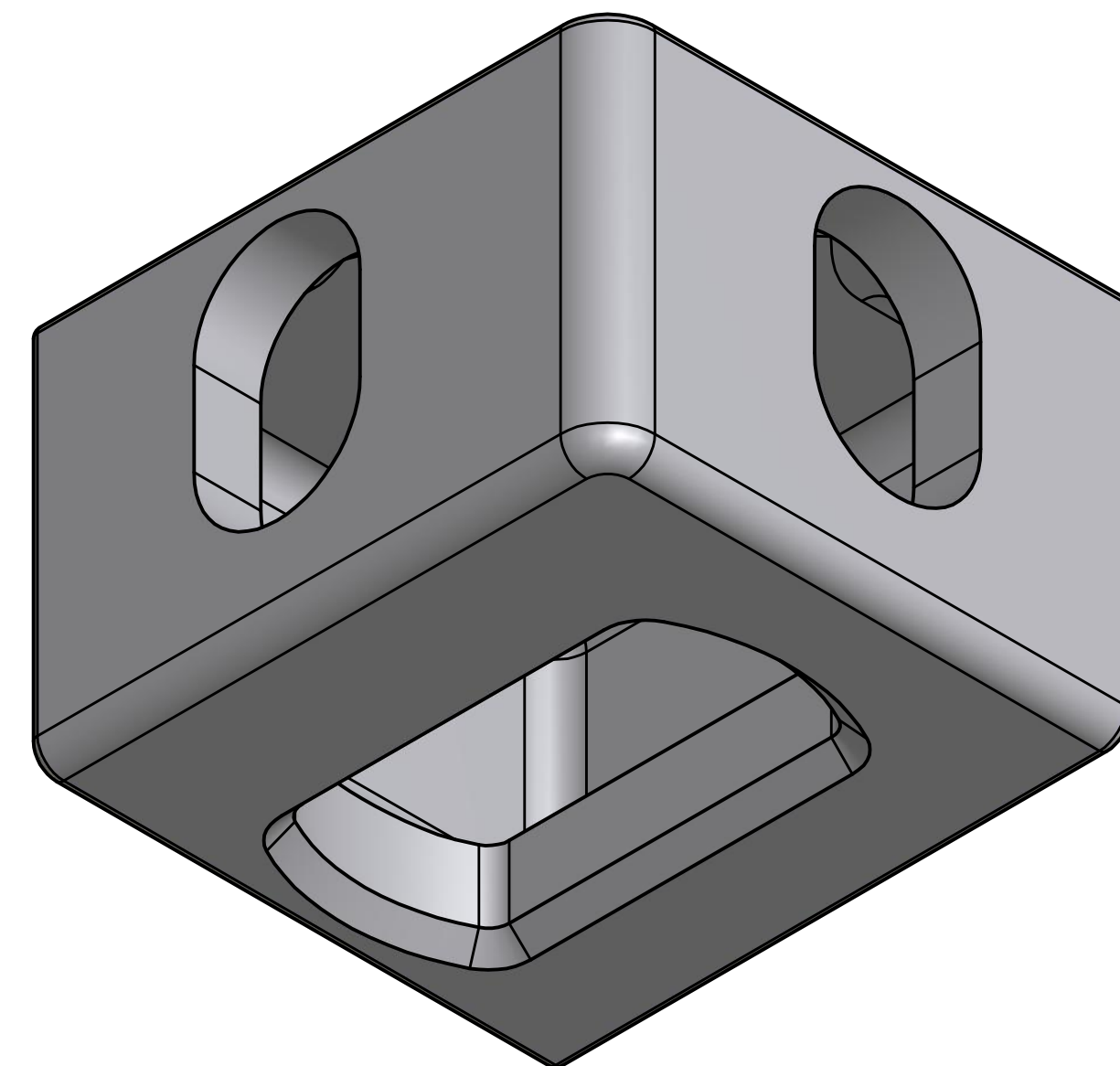
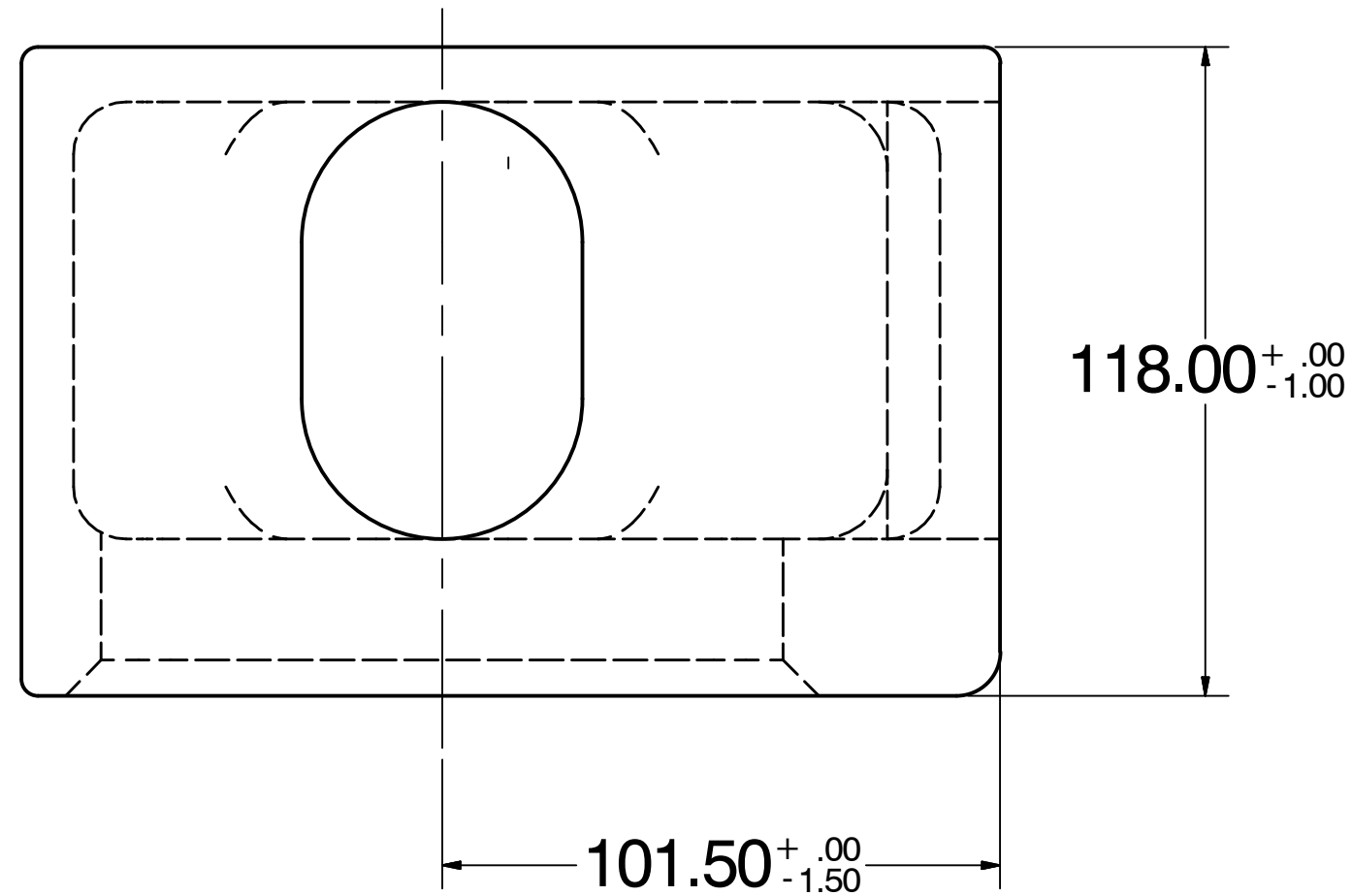

LH SHOWN (RH OPPOSITE)

CC	FEATURES LABELED AS SUCH SHALL REQUIRE STATISTICAL PROCESS CONTROL
SC	FEATURES LABELED AS SUCH REQUIRE REFERENCE TO A CONTROL PLAN

SHEET 1 OF 1	INITIALS DATE	DR. 07/21/10	CK. -	ENGR. -	MFG. -	QUAL. -	MATL. -
COUNTRY OF ORIGIN	UNITS MILLIMETERS	3RD ANGLE PROJECTION	DO NOT SCALE PLOT SCALE 1:1 DRAWING SCALE NTS				
<p>GEOMETRIC TOLERANCE SYMBOLS</p> <ul style="list-style-type: none"> <li>CONCENTRICITY</li> <li>SYMMETRICAL</li> <li>PARALLELISM</li> <li>FLATNESS</li> <li>PROFILE OF A SURFACE</li> <li>LEAST MATERIAL CONDITION</li> <li>REGARDLESS OF FEATURE SIZE</li> <li>POSITION</li> <li>CIRCULARITY</li> <li>CYLINDRICITY</li> <li>TOTAL RUNOUT</li> <li>BASIC DIMENSION</li> <li>DATUM</li> <li>PERPENDICULARITY</li> <li>STRAIGHTNESS</li> <li>ANGULARITY</li> <li>CIRCULAR RUNOUT</li> <li>PROFILE OF A LINE</li> </ul>				<p>This drawing is the property of Krisry International Inc. It is furnished to you for confidential information purposes only. It is not to be disclosed to anyone else, reproduced, or used for manufacturing purposes without the express written permission of Krisry International Inc.</p>			
DRAWING TITLE <b>CORNER CASTING (LOWER)</b>							REV
DRAWING NUMBER <b>BLR 20000</b>							DWG SIZE <b>C</b>

KRISRY INTERNATIONAL INC.  
(847) 487-4907 - phone  
1000 N. Rand Road, Suite 117  
Wauconda, Illinois 60084